

<b>ROBOTINA d.o.o.</b> Oprema in sistemi za avtomatizacijo TEL: 05 66 32 420 Ident. št.: IZS 1628	verzija:	PID 1.0	ident. št.:	E-1012	datum:	24.09.01	podpis:		Pristaniški žerjav z grabilcem 20/10Mp x 25/30m 	LUKA KOPER d.d. PC Terminal Sipki Tovori Investitor	KRMILNA NAPETOST IN KRMILJE GLAVNEGA VKLOPA Št. projekta: <b>01-06-023</b>	NAP =0 +L1, L2	
	odg. proj.:	Ivan Morano											
	risal:												
	pregledal:												
									Objekt		Skupina	Stran: 2 Strani: 38	

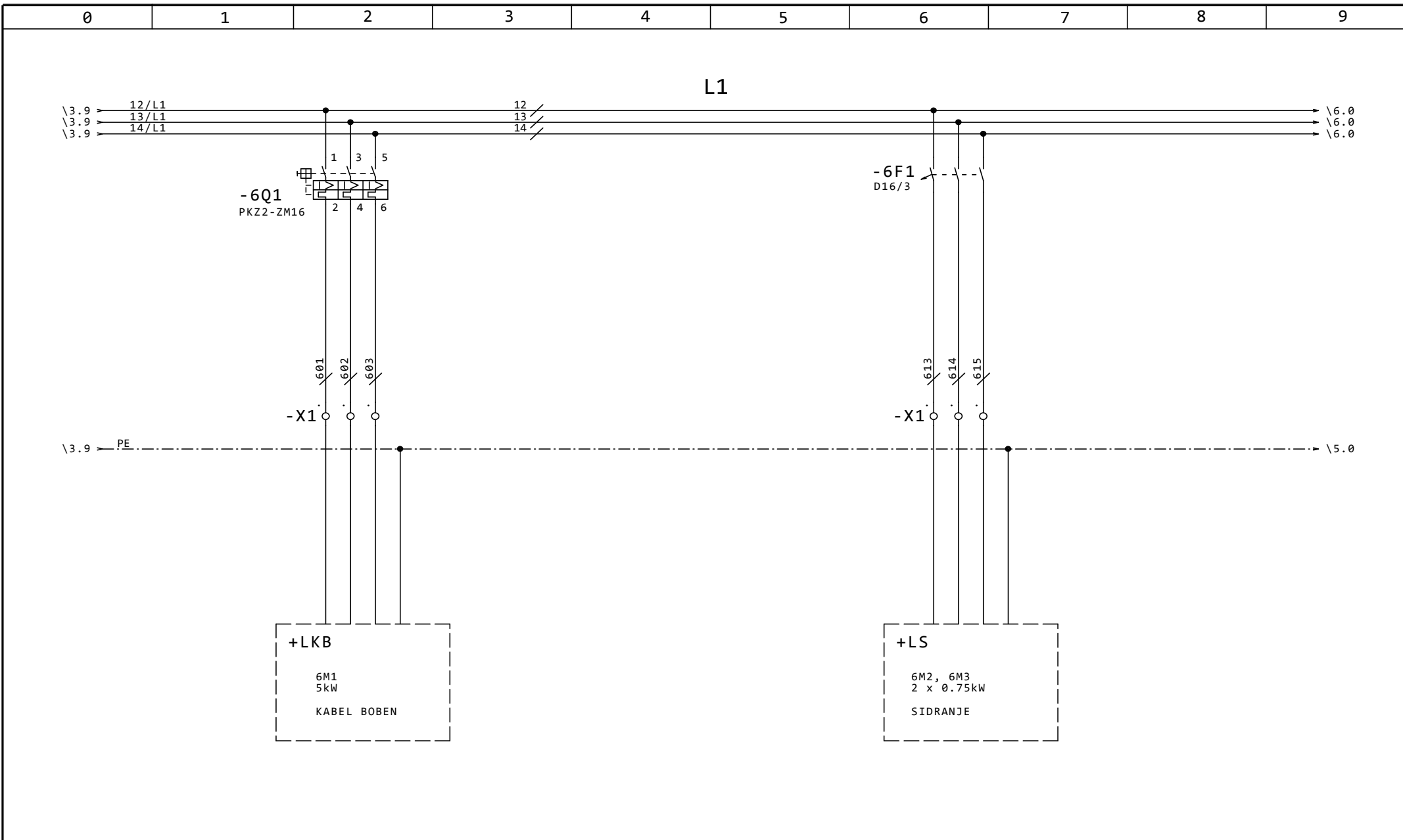



 <b>ROBOTINA d.o.o.</b> Oprema in sistemi za avtomatizacijo TEL: 05 66 32 420 Ident. št.: IZS 1628	verzija:	PID 1.0	ident. št.:	datum:	podpis:	Pristaniški žerjav z grabilcem 20/10Mp x 25/30m 	LUKA KOPER d.d. PC Terminal Sipki Tovori	KABEL BOBEN IN SIDRANJE DVGALA ENERGETSKI DEL V L1		KBS	=6		
	odg. proj.:	Ivan Morano	E-1012	24.09.01							+L1		
	risal:												Stran: 4
	pregledal:												Strani: 38
					Objekt	Investitor	Št. projekta: 01-06-023		-2-04-6/1 Skupina				



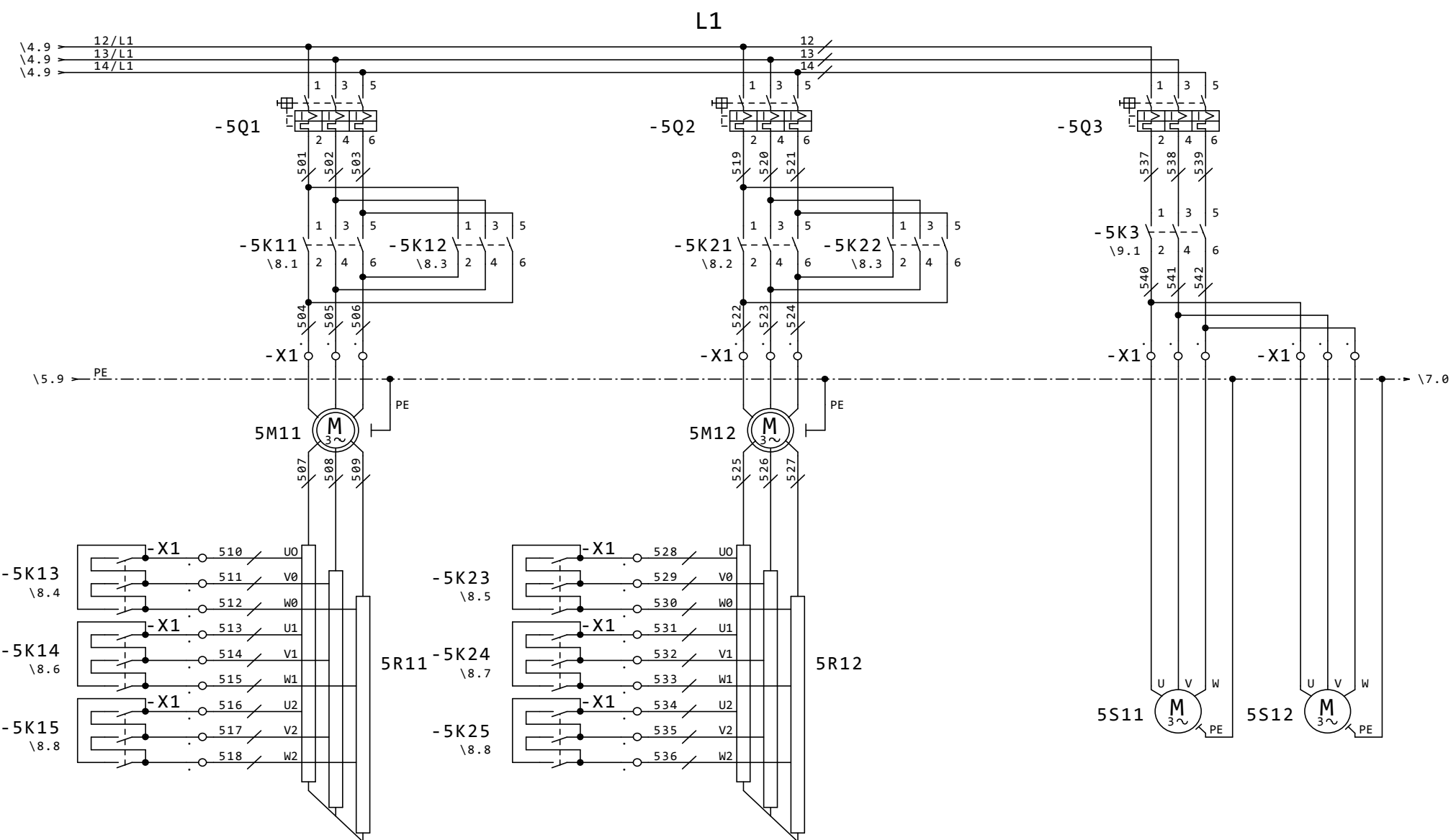

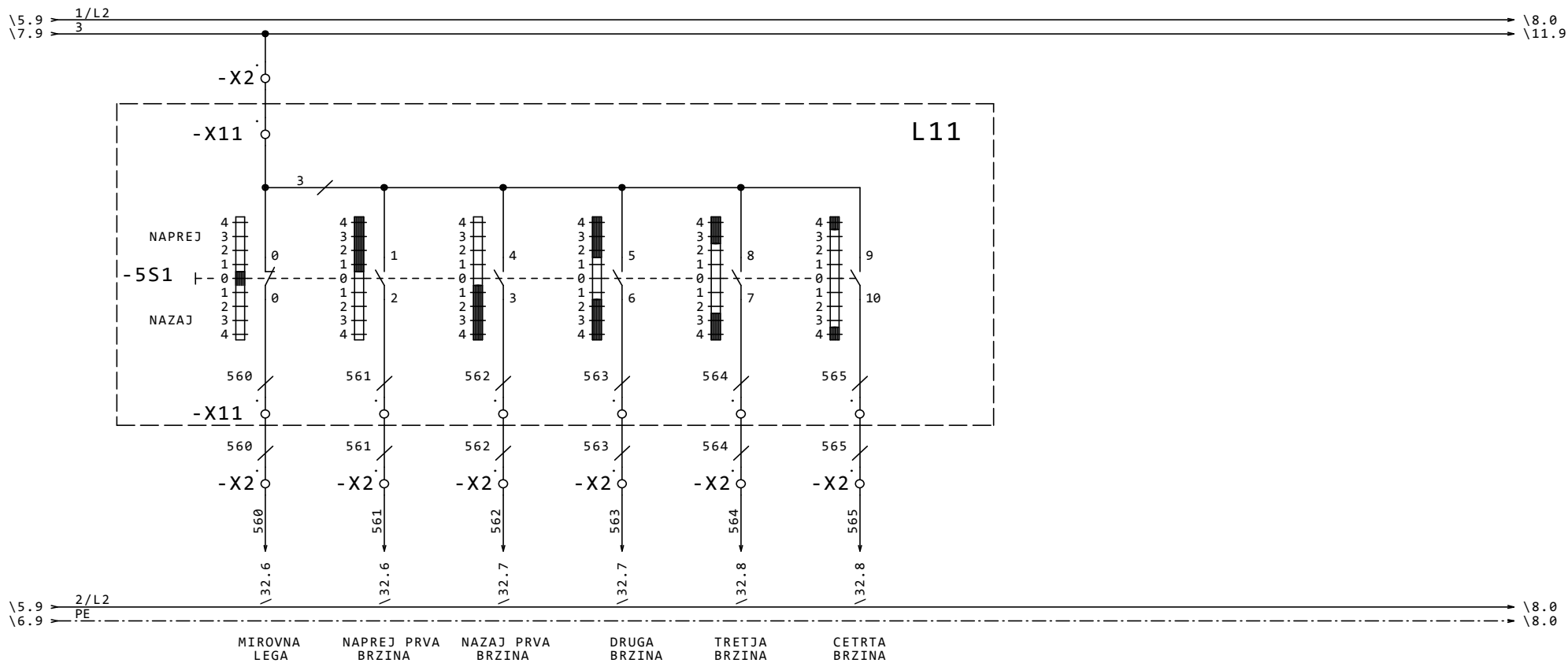

0	1	2	3	4	5	6	7	8	9
---	---	---	---	---	---	---	---	---	---

## L2



### MOJSTRSKO STIKALO VOZNJE

 <b>ROBOTINA d.o.o.</b> Oprema in sistemi za avtomatizacijo TEL: 05 66 32 420 Ident. št.: IZS 1628	verzija:	PID 1.0	ident. št.:	E-1012	datum:	24.09.01	podpis:		Pristaniški žerjav z grabilcem 20/10Mp x 25/30m 	LUKA KOPER d.d. PC Terminal Sipki Tovori	VOŽNJA DVIGALA KRMILNI DEL V L12	V	=5
	odg. proj.:	Ivan Morano											+L12
	risal:									Objekt	Investitor	Št. projekta: 01-06-023	-2-04-5/2 Skupina

0	1	2	3	4	5	6	7	8	9
---	---	---	---	---	---	---	---	---	---

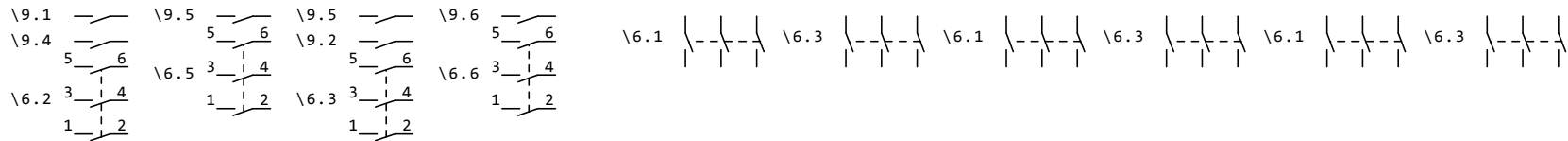
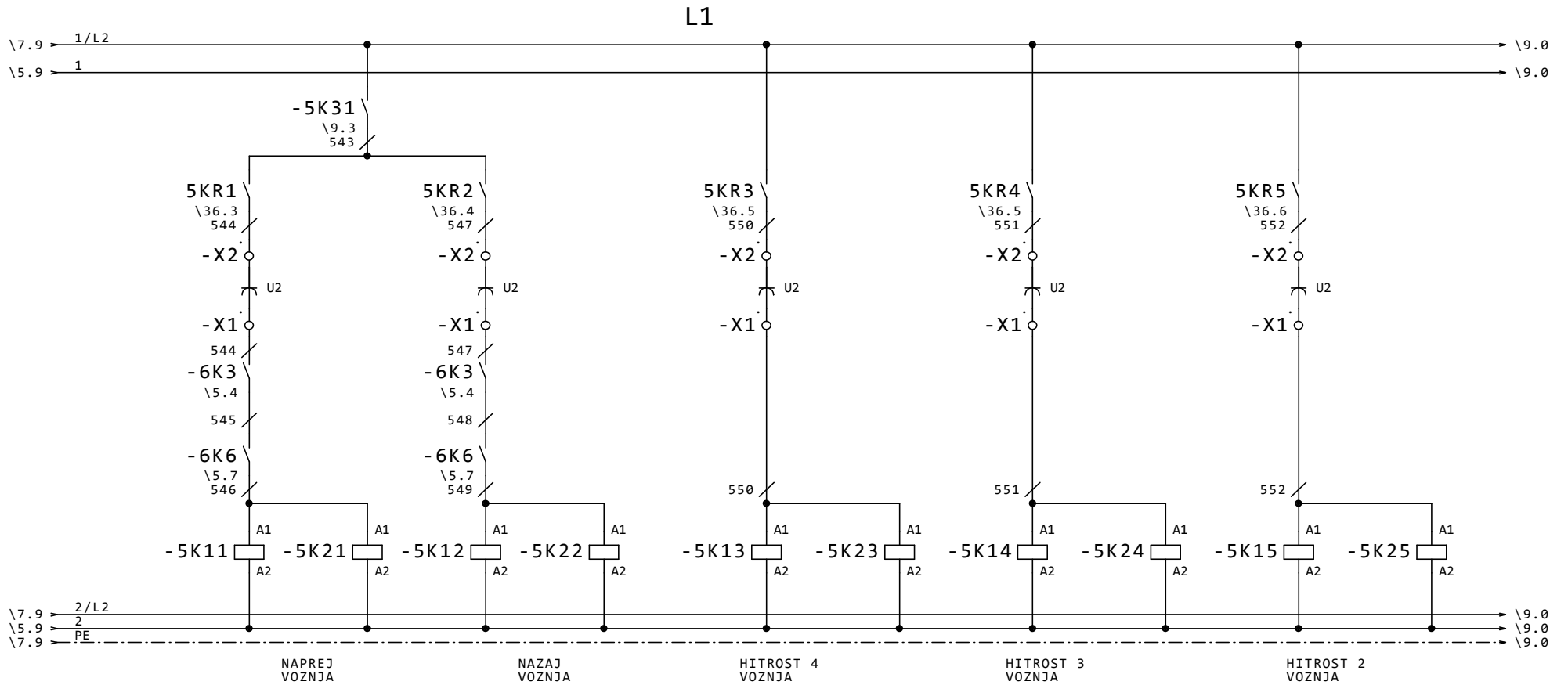

<b>ROBOTINA d.o.o.</b> Oprema in sistemi za avtomatizacijo TEL: 05 66 32 420 Ident. št.: IZS 1628	verzija:	PID 1.0	ident. št.:	datum:	podpis:	Pristaniški žerjav z grabilcem 20/10Mp x 25/30m 	LUKA KOPER d.d. PC Terminal Sipki Tovori	VOŽNJA DVIGALA KRMILNI DEL V L1 IN L2		V	=5		
	odg. proj.:	Ivan Morano	E-1012	24.09.01				Objekt	Investitor	Št. projekta: 01-06-023		-2-04-5/3	Stran: 8
	risal:									Skupina	Strani: 38		
	pregledal:												









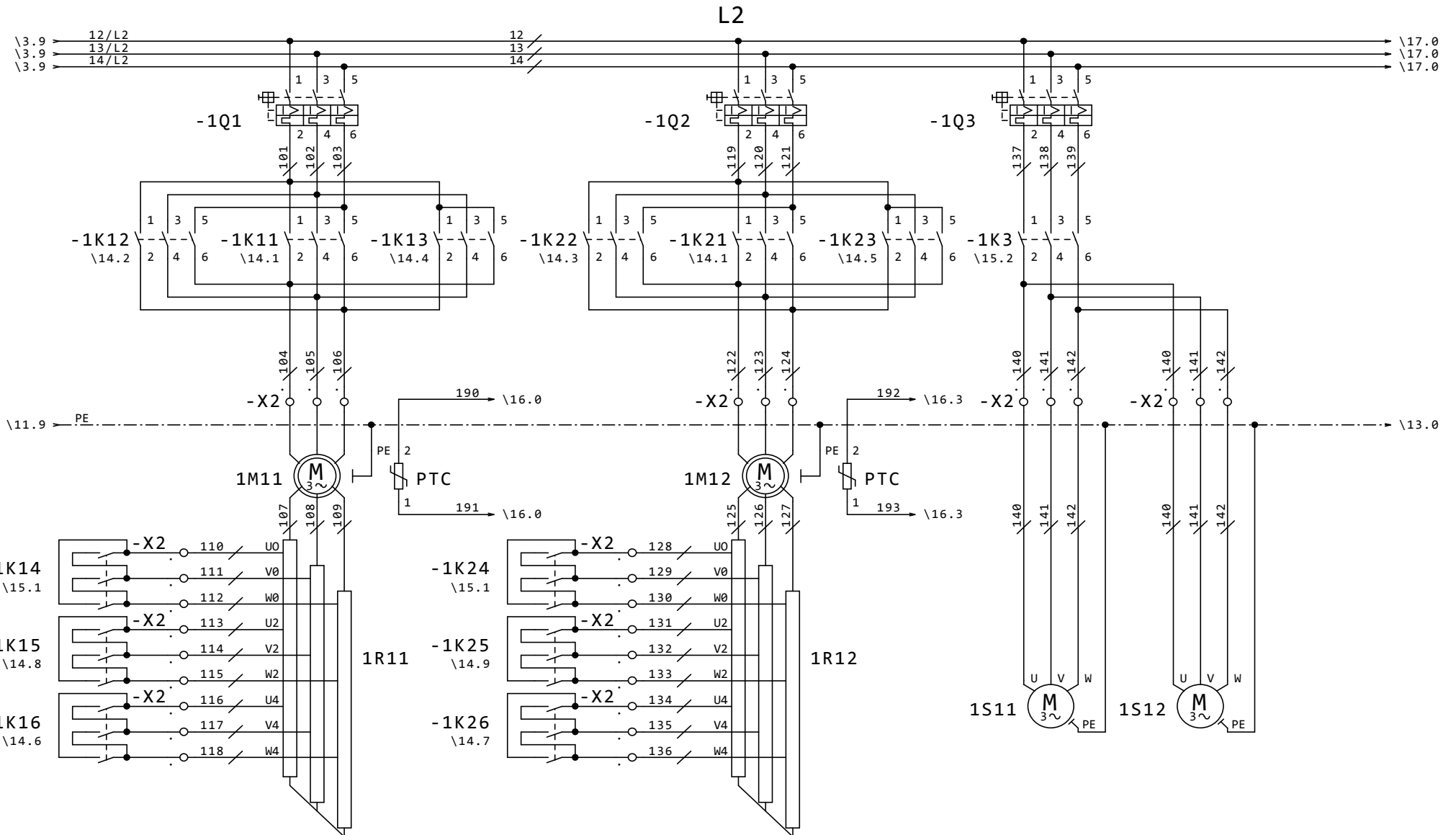

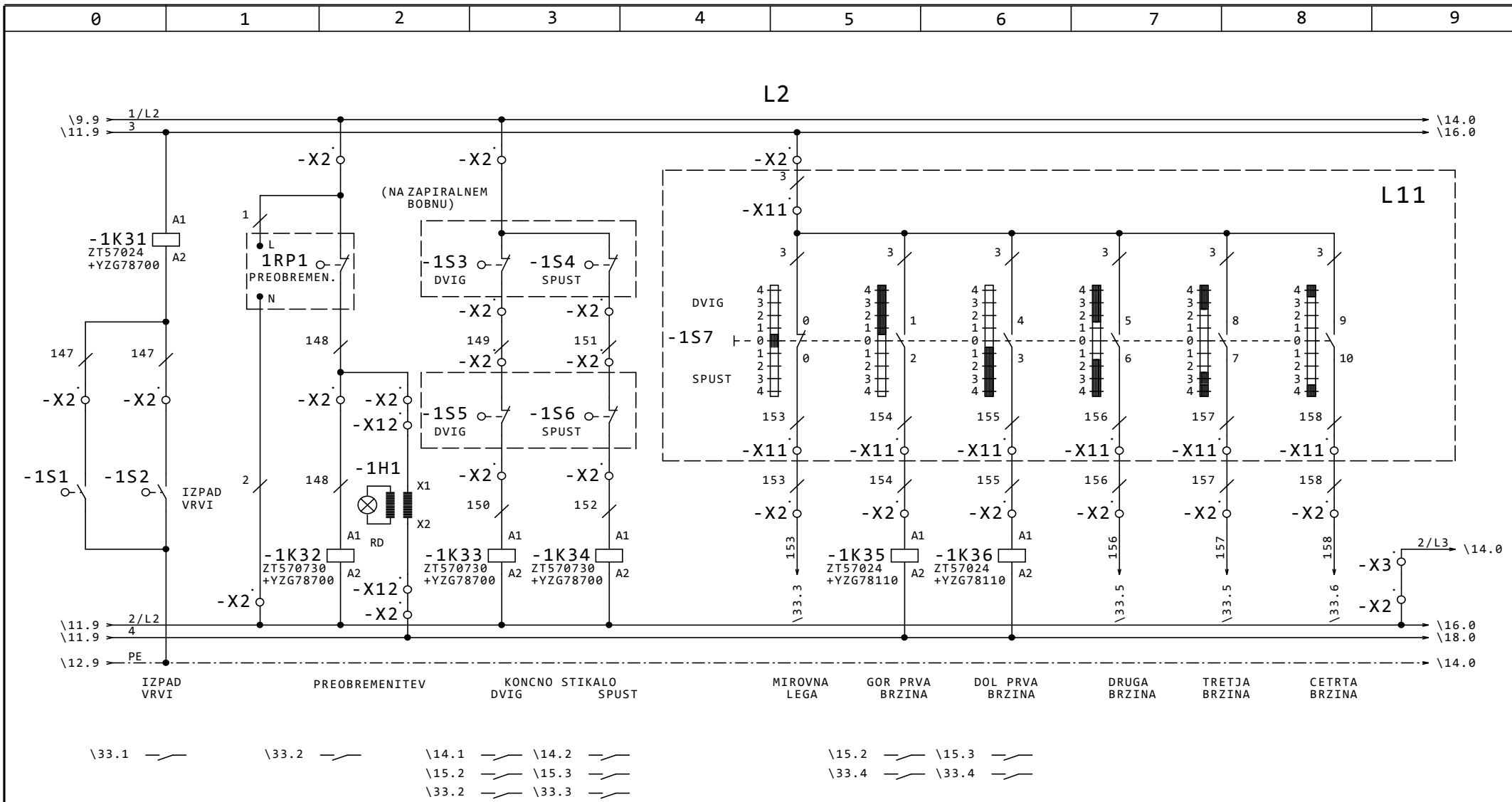

MOJSTRSKO STIKALO DVIGA

<b>ROBOTINA d.o.o.</b> Oprema in sistemi za avtomatizacijo TEL: 05 66 32 420 Ident. št.: IZS 1628	verzija:	PID 1.0	ident. št.:	datum:	podpis:	Pristaniški žerjav z grablincem 20/10Mp x 25/30m 	LUKA KOPER d.d. PC Terminal Sipki Tovori	DVIG KRMILNI DEL V L2		D =1 +L2			
	odg. proj.:	Ivan Morano	E-1012	24.09.01				Objekt	Investitor		Št. projekta: 01-06-023		
	risal:										-2-04-1/2		Stran: 13
	pregledal:										Skupina		Strani: 38

0	1	2	3	4	5	6	7	8	9
---	---	---	---	---	---	---	---	---	---

L2

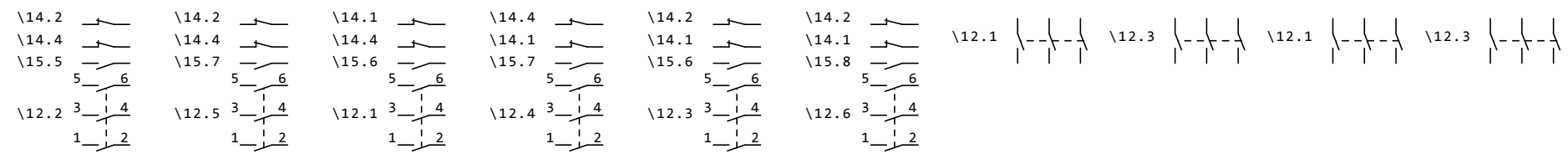
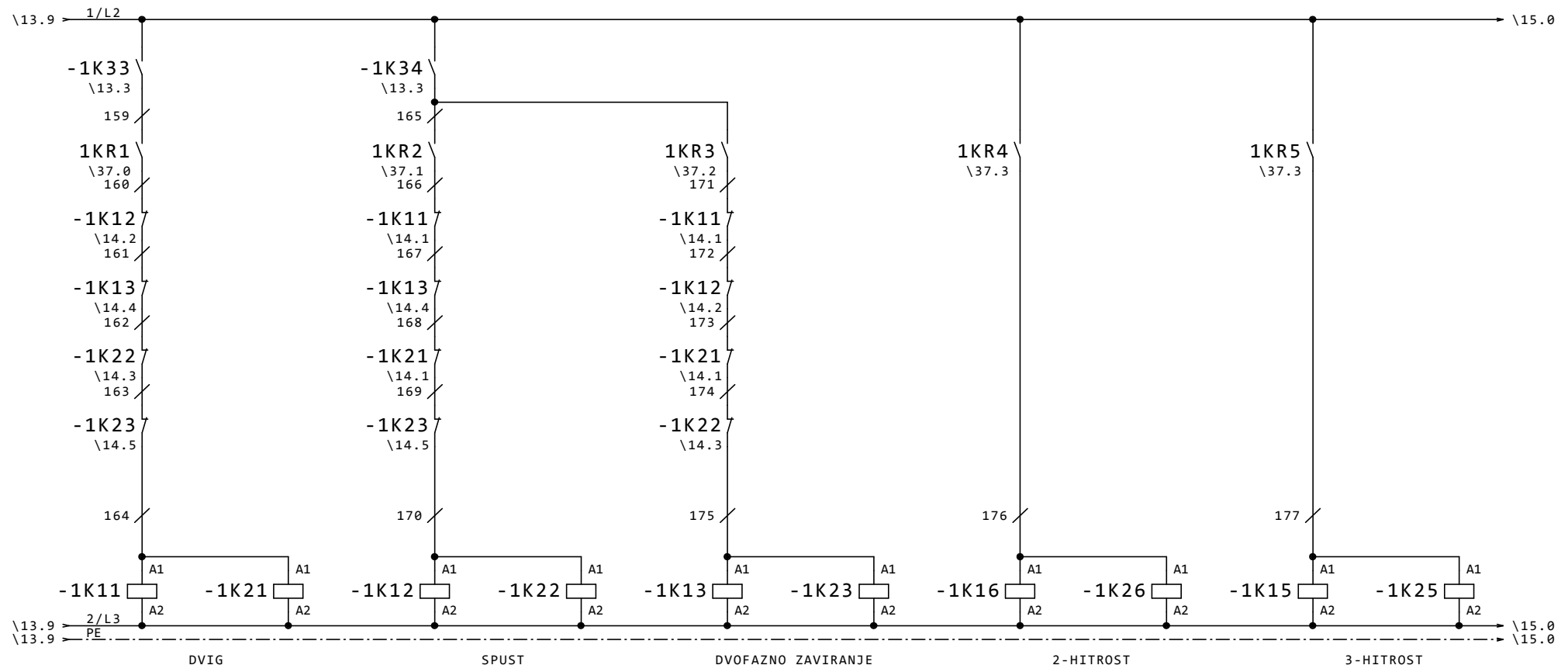

<b>ROBOTINA d.o.o.</b> Oprema in sistemi za avtomatizacijo TEL: 05 66 32 420 Ident. št.: IZS 1628	verzija:	PID 1.0	ident. št.:	E-1012	datum:	24.09.01	podpis:	Pristaniški žerjav z grabilcem 20/10Mp x 25/30m 	LUKA KOPER d.d. PC Terminal Sipki Tovori Investitor	DVIG	KRMILNI DEL V L2 IN L3 D =1 +L2, L3	Št. projekta: 01-06-023 Skupina	-2-04-1/3 Stran: 14 Strani: 38
	odg. proj.:	Ivan Morano					Objekt			-2-04-1/3 Stran: 14 Strani: 38			
	risal:												
pregledal:													

0	1	2	3	4	5	6	7	8	9
---	---	---	---	---	---	---	---	---	---

L2

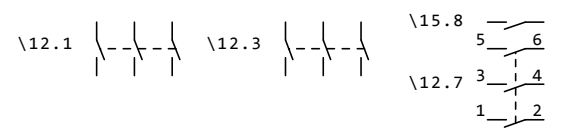
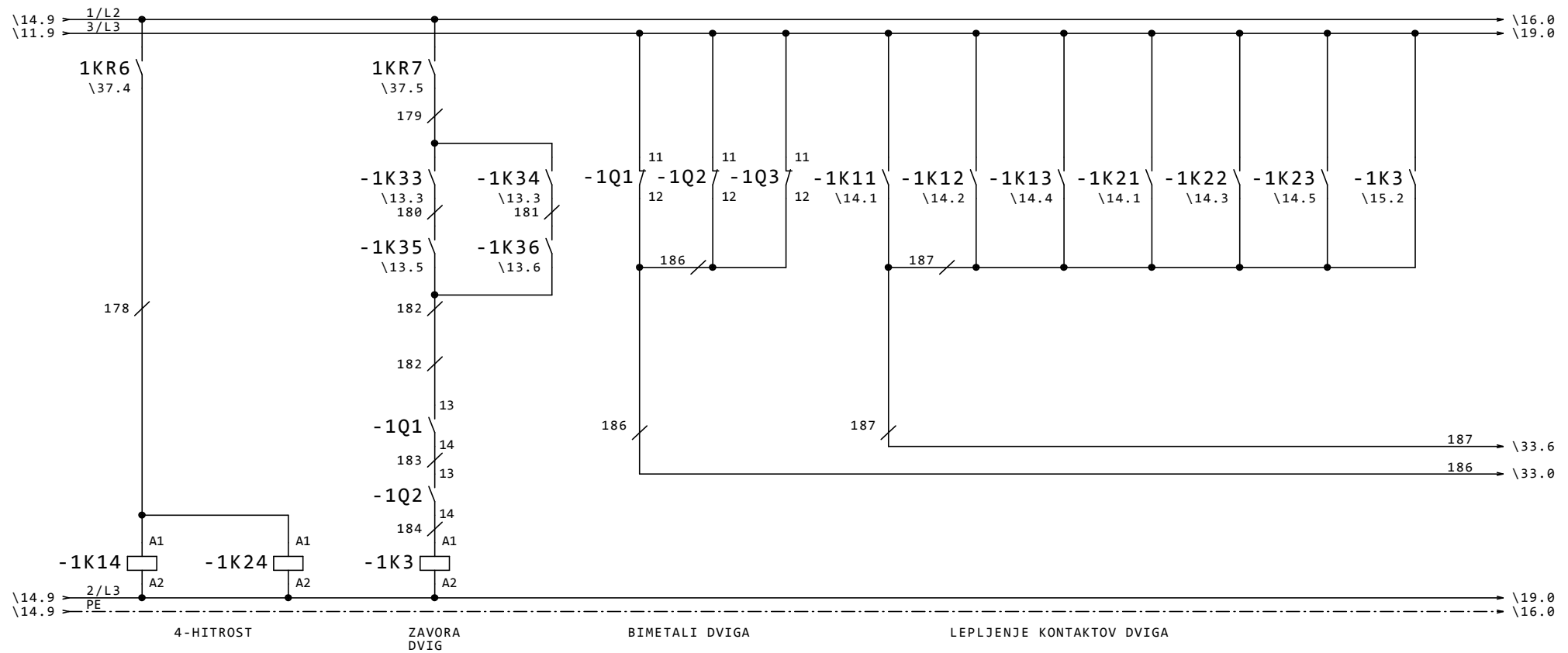

<b>ROBOTINA d.o.o.</b> Oprema in sistemi za avtomatizacijo TEL: 05 66 32 420 Ident. št.: IZS 1628	verzija:	PID 1.0	ident. št.:	E-1012	datum:	24.09.01	podpis:		Pristaniški žerjav z grabilcem 20/10Mp x 25/30m 	LUKA KOPER d.d. PC Terminal Sipki Tovori	DVIG	D	=1
	odg. proj.:	Ivan Morano						KRMILNI DEL V L2 IN L3			+L2, L3		
	risal:								Objekt	Investitor	Št. projekta: 01-06-023	-2-04-1/4	Stran: 15
	pregledal:										Skupina		Strani: 38

0	1	2	3	4	5	6	7	8	9
---	---	---	---	---	---	---	---	---	---

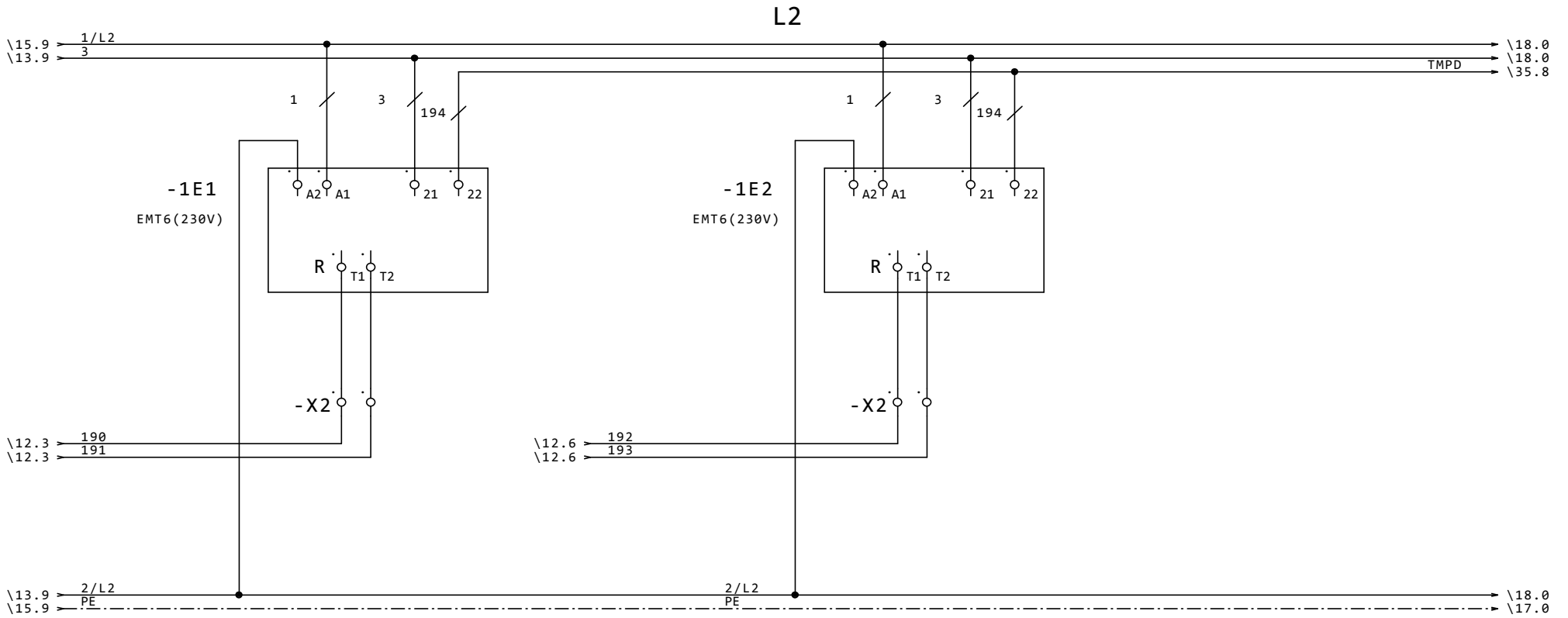

<b>ROBOTINA d.o.o.</b> Oprema in sistemi za avtomatizacijo TEL: 05 66 32 420 Ident. št.: IZS 1628	verzija:	PID 1.0	ident. št.:	E-1012	datum:	24.09.01	podpis:		Pristaniški žerjav z grabilcem 20/10Mp x 25/30m 	LUKA KOPER d.d. PC Terminal Sipki Tovori	DVIG KRMILNI DEL V L2	D	=1
	odg. proj.:	Ivan Morano						+L2					
	risal:								Objekt	Investitor	Št. projekta: 01-06-023	-2-04-1/5	Stran: 16
	pregledal:											Skupina	Strani: 38



0	1	2	3	4	5	6	7	8	9
---	---	---	---	---	---	---	---	---	---

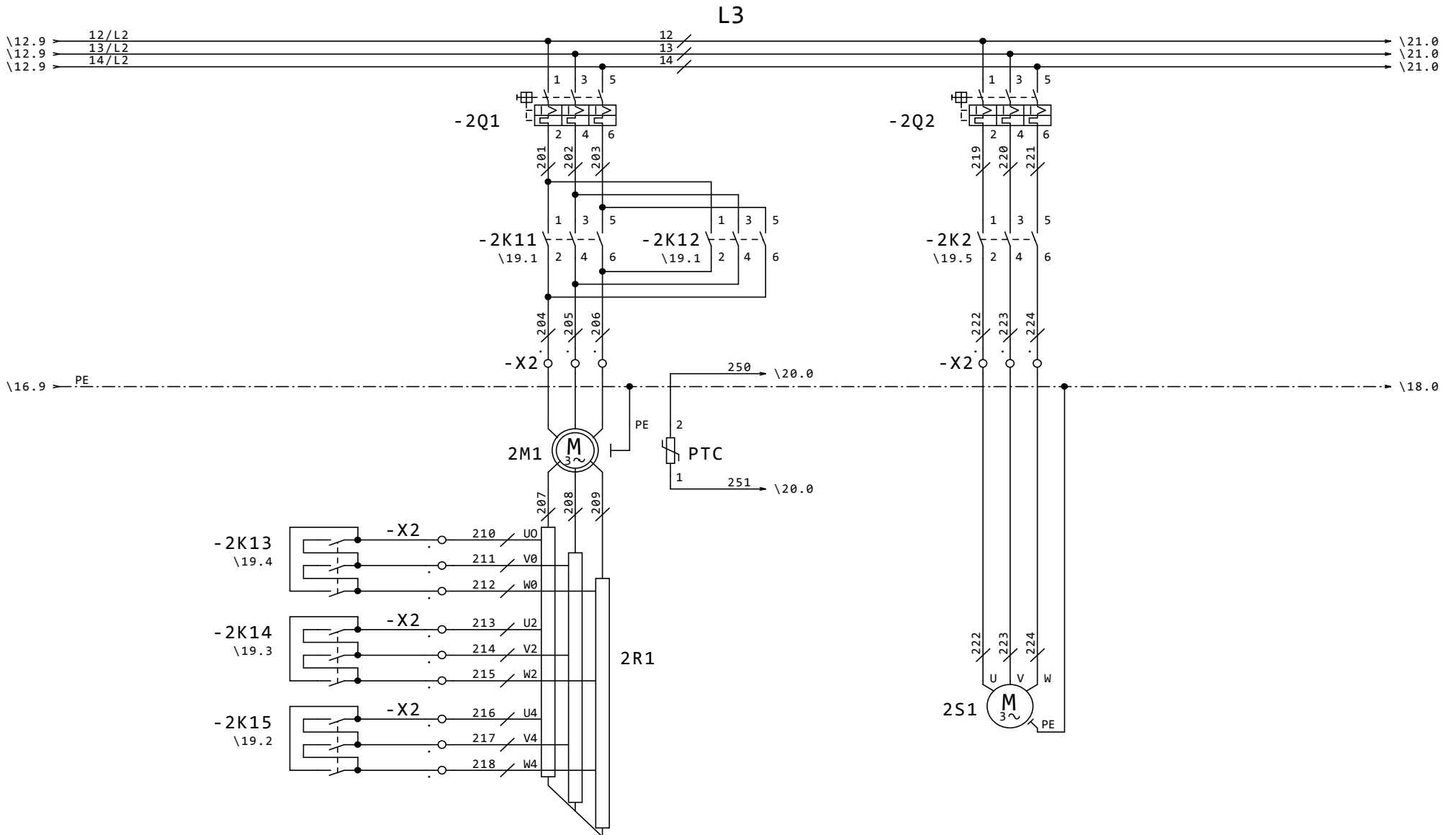

<b>ROBOTINA d.o.o.</b> Oprema in sistemi za avtomatizacijo TEL: 05 66 32 420 Ident. št.: IZS 1628	verzija:	PID 1.0	ident. št.:	E-1012	datum:	24.09.01	podpis:		Pristaniški žerjav z grabilcem 20/10Mp x 25/30m 	LUKA KOPER d.d. PC Terminal Sipki Tovori Investitor	GRABILEC ENERGETSKI DEL V L3		G	=2
	odg. proj.:	Ivan Morano									-2-04-2/1			Stran: 17
	pregledal:										Skupina			Strani: 38

0	1	2	3	4	5	6	7	8	9
---	---	---	---	---	---	---	---	---	---

L2

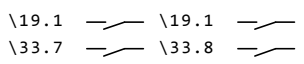
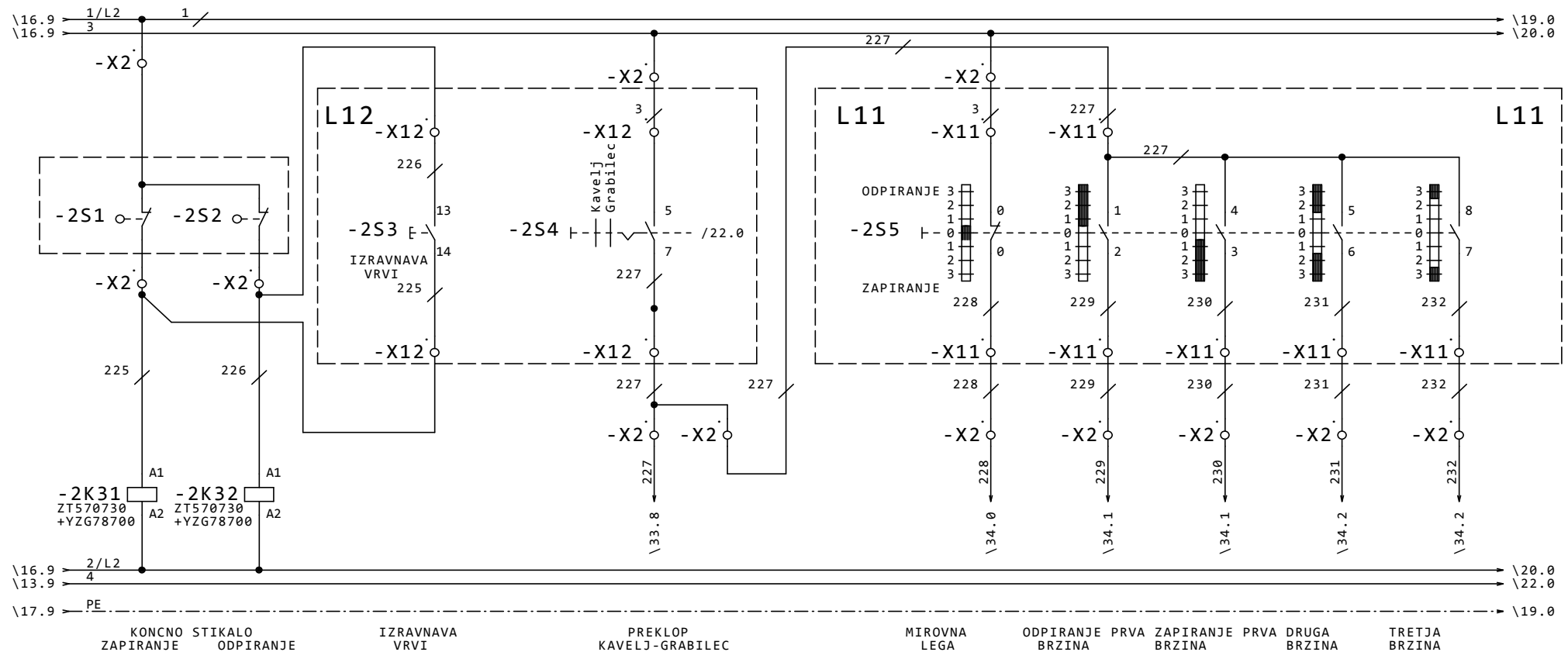

MOJSTRSKO STIKALO GRABILCA

<b>ROBOTINA d.o.o.</b> Oprema in sistemi za avtomatizacijo TEL: 05 66 32 420 Ident. št.: IZS 1628	verzija:	PID 1.0	ident. št.:	E-1012	datum:	24.09.01	podpis:		Pristaniški žerjav z grabilcem 20/10Mp x 25/30m Objekt	LUKA KOPER d.d. PC Terminal Sipki Tovori Investitor	GRABILEC KRMILNI DEL V L2 Št. projekta: 01-06-023	G	=2 +L2
	odg. proj.:	Ivan Morano	risal:		pregledal:			-2-04-2/2 Skupina				Stran: 18 Strani: 38	

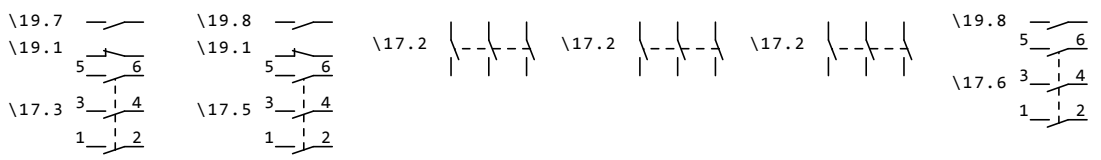
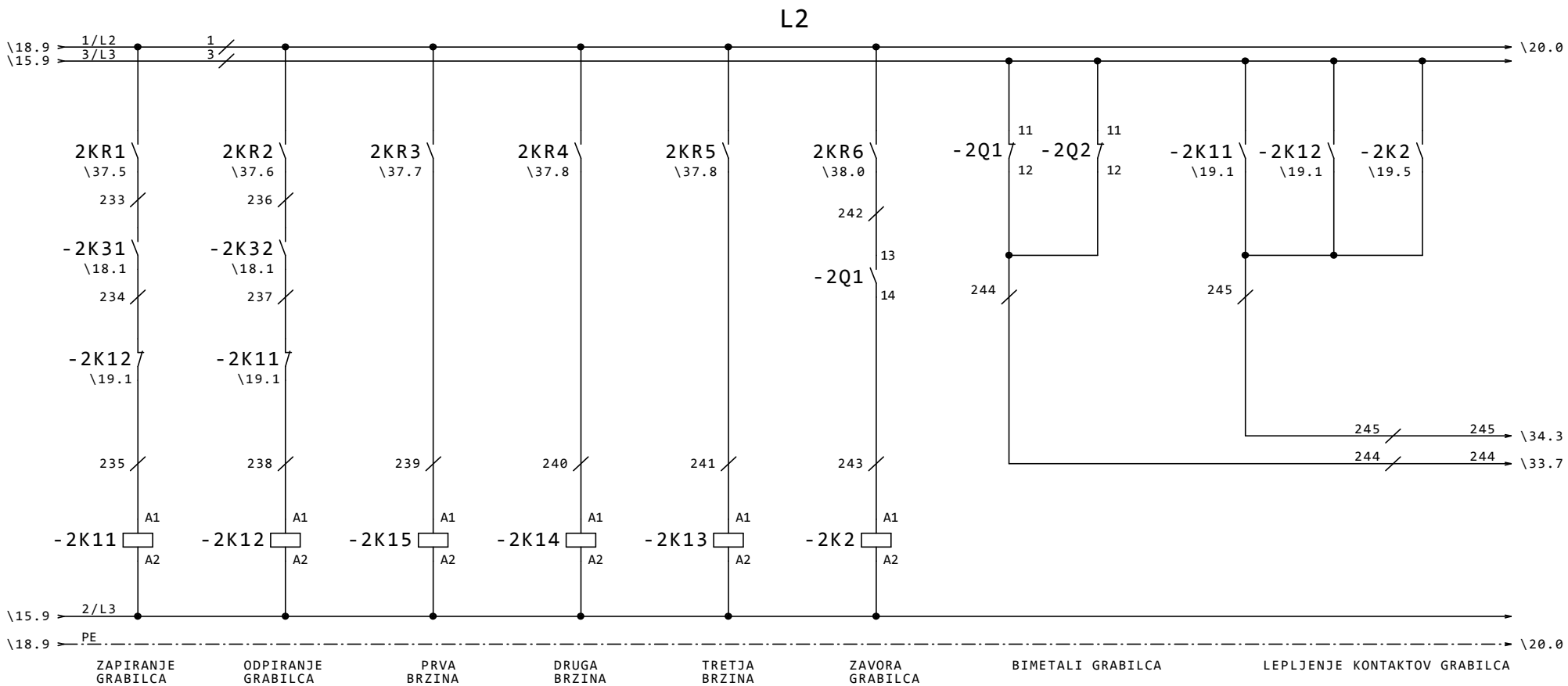

0	1	2	3	4	5	6	7	8	9
---	---	---	---	---	---	---	---	---	---

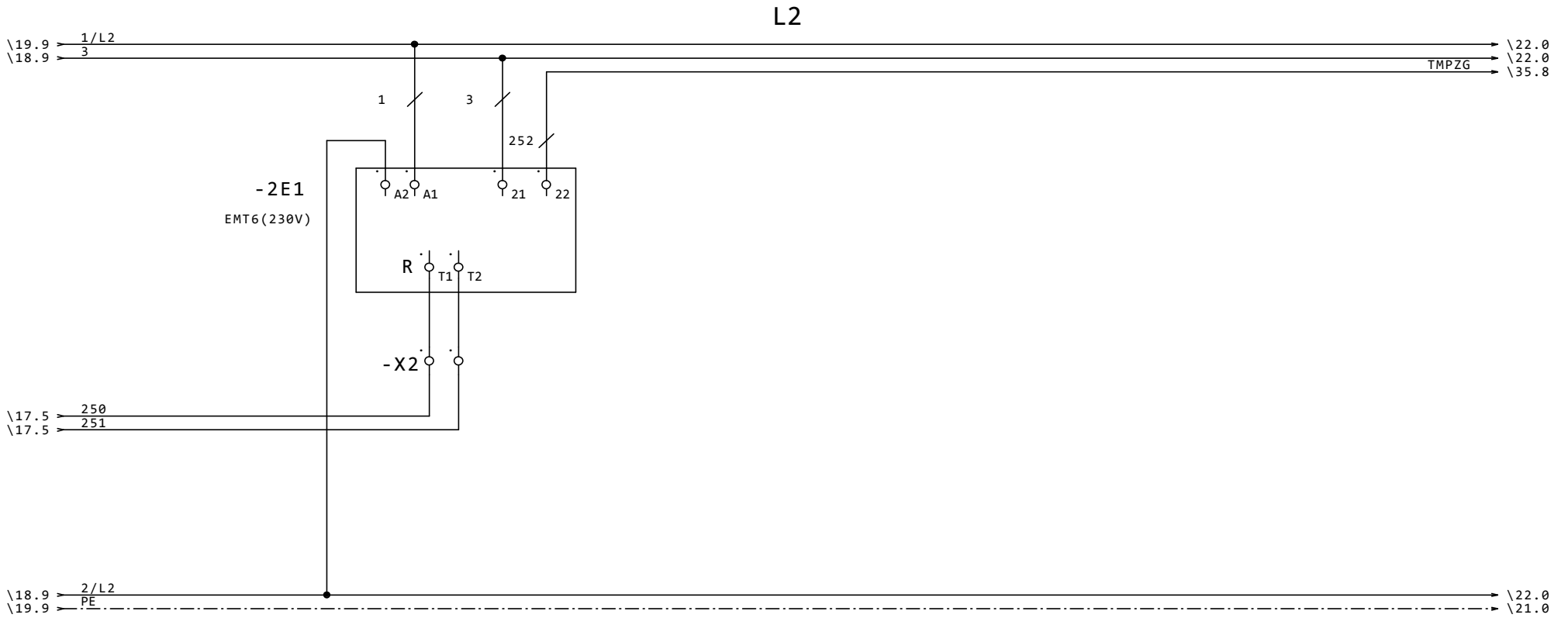

<b>ROBOTINA d.o.o.</b> Oprema in sistemi za avtomatizacijo TEL: 05 66 32 420 Ident. št.: IZS 1628	verzija:	PID 1.0	ident. št.:	E-1012	datum:	24.09.01	podpis:	Pristaniški žerjav z grabilcem 20/10Mp x 25/30m 	LUKA KOPER d.d. PC Terminal Sipki Tovori	GRABILEC KRMILNI DEL V L2 IN L3	G	=2 +L2, L3
	odg. proj.:	Ivan Morano										
	risal:											
	pregledal:											
Objekt								Investitor	Št. projekta: 01-06-023		-2-04-2/3 Skupina	Stran: 19 Strani: 38

0	1	2	3	4	5	6	7	8	9
---	---	---	---	---	---	---	---	---	---



 <b>ROBOTINA d.o.o.</b> Oprema in sistemi za avtomatizacijo TEL: 05 66 32 420 Ident. št.: IZS 1628	verzija:	PID 1.0	ident. št.:	E-1012	datum:	24.09.01	podpis:		Pristaniški žerjav z grabilcem 20/10Mp x 25/30m 	LUKA KOPER d.d. PC Terminal Sipki Tovori	GRABILEC KRMILNI DEL V L2	G	=2			
	odg. proj.:	Ivan Morano						+L2								
	risal:													Št. projekta: 01-06-023	-2-04-2/4	Stran: 20
	pregledal:									Objekt	Investitor			Skupina	Strani: 38	





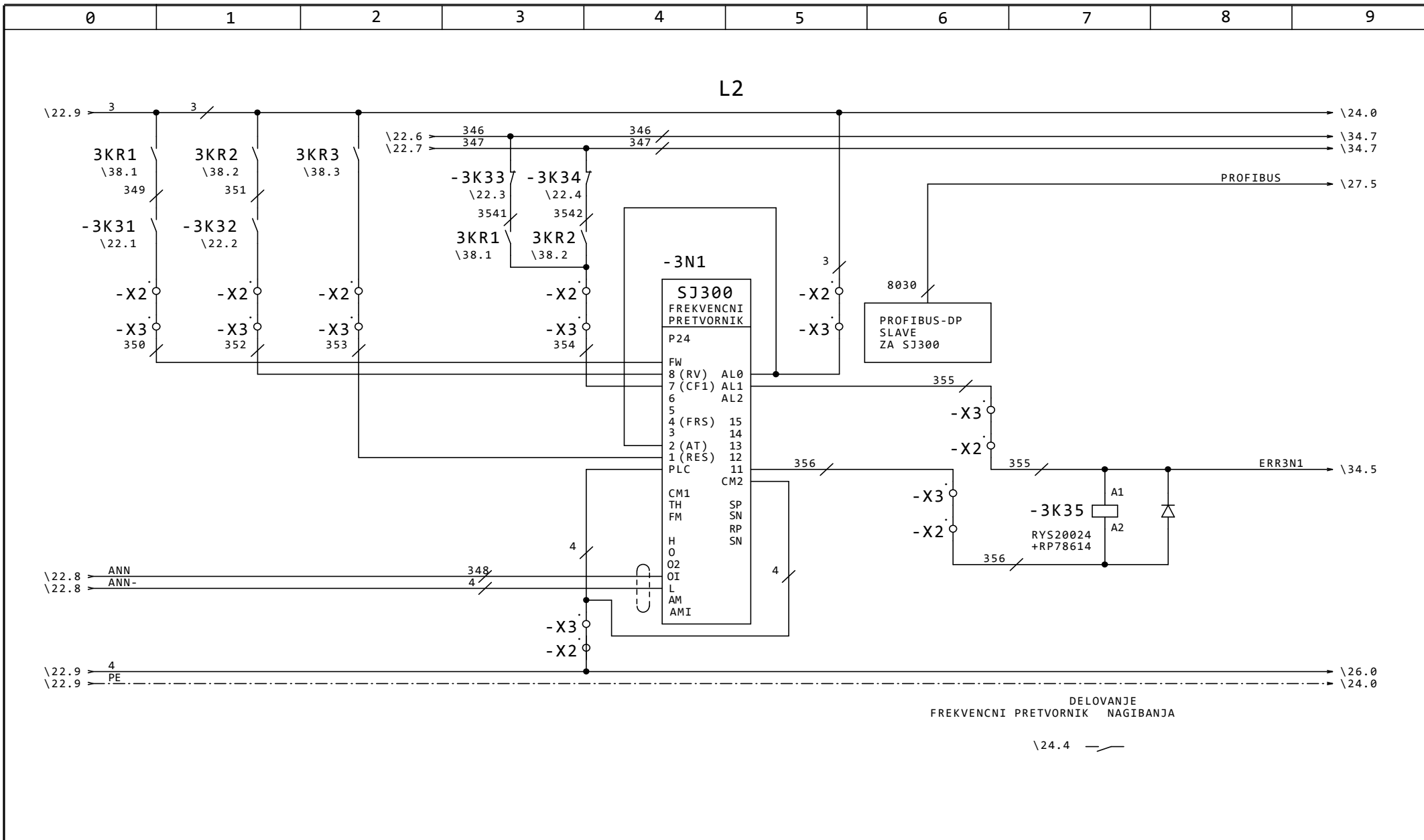

	ROBOTINA d.o.o.	verzija: PID 1.0	ident. št.: E-1012	datum: 24.09.01	podpis:	Pristaniški žerjav z grabilcem	LUKA KOPER d.d.	NAGIBANJE ROČICE	N	=3
	Oprema in sistemi za avtomatizacijo	odg. proj.: Ivan Morano				20/10Mp x 25/30m	PC Terminal Sipki	KRMILNI DEL V L2		+L2
	TEL: 05 66 32 420 Ident. št.: IZS 1628	risal:				Objekt	Tovori	Investitor	Št. projekta: 01-06-023	-2-04-3/3
	pregledal:							Skupina		Strani: 38





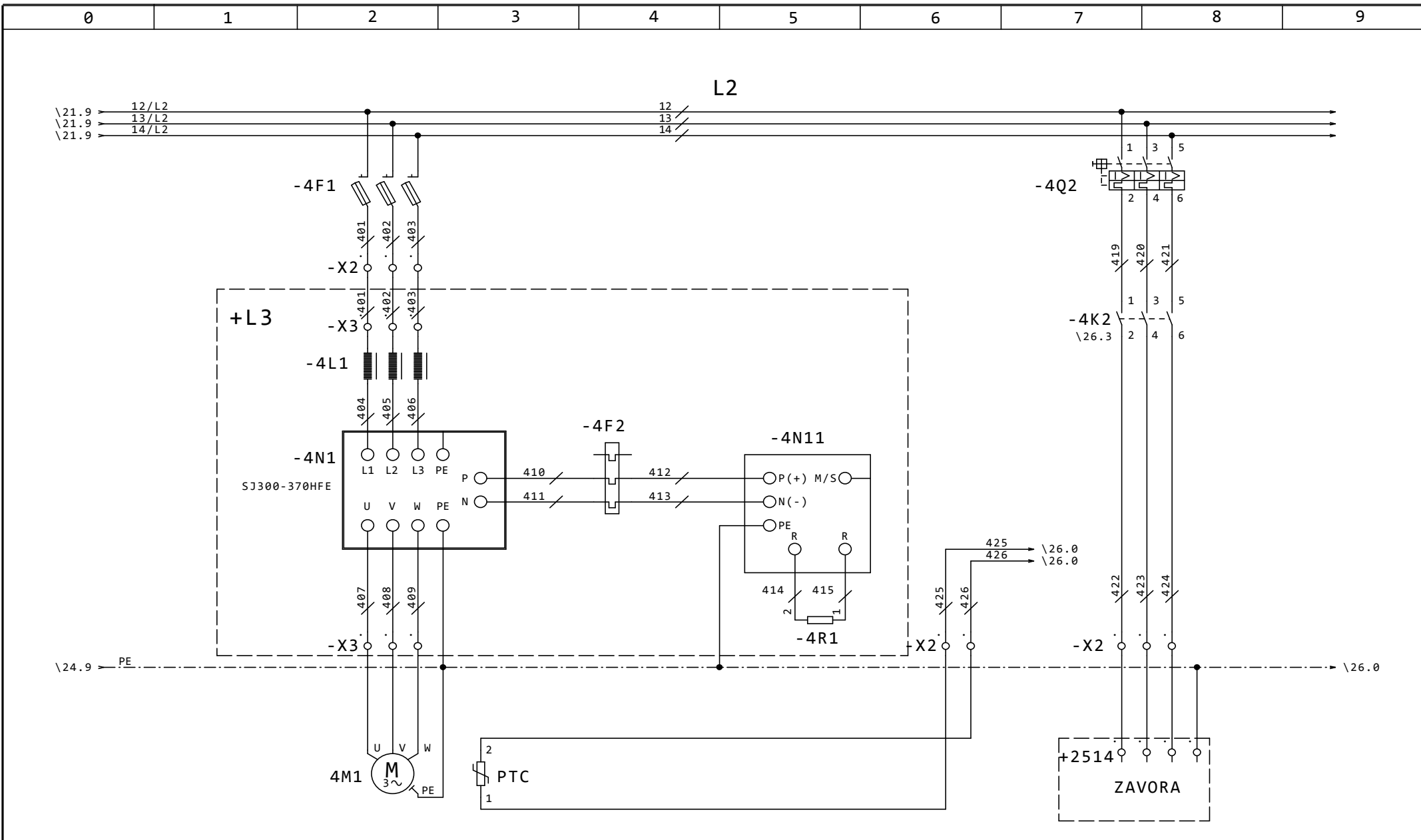

<b>ROBOTINA d.o.o.</b> Oprema in sistemi za avtomatizacijo TEL: 05 66 32 420 Ident. št.: IZS 1628	verzija:	PID 1.0	ident. št.:	E-1012	datum:	24.09.01	podpis:		Pristaniški žerjav z grabilcem 20/10Mp x 25/30m 	LUKA KOPER d.d. PC Terminal Sipki Tovori Investitor	OBRAČUNJE ENERGETSKI DEL V L2		0	=4	
	odg. proj.:	Ivan Morano													
	risal:														
pregledal:									Objekt		Št. projekta: 01-06-023	-2-04-4/1	Stran: 25		
											Skupina		Strani: 38		

### L2

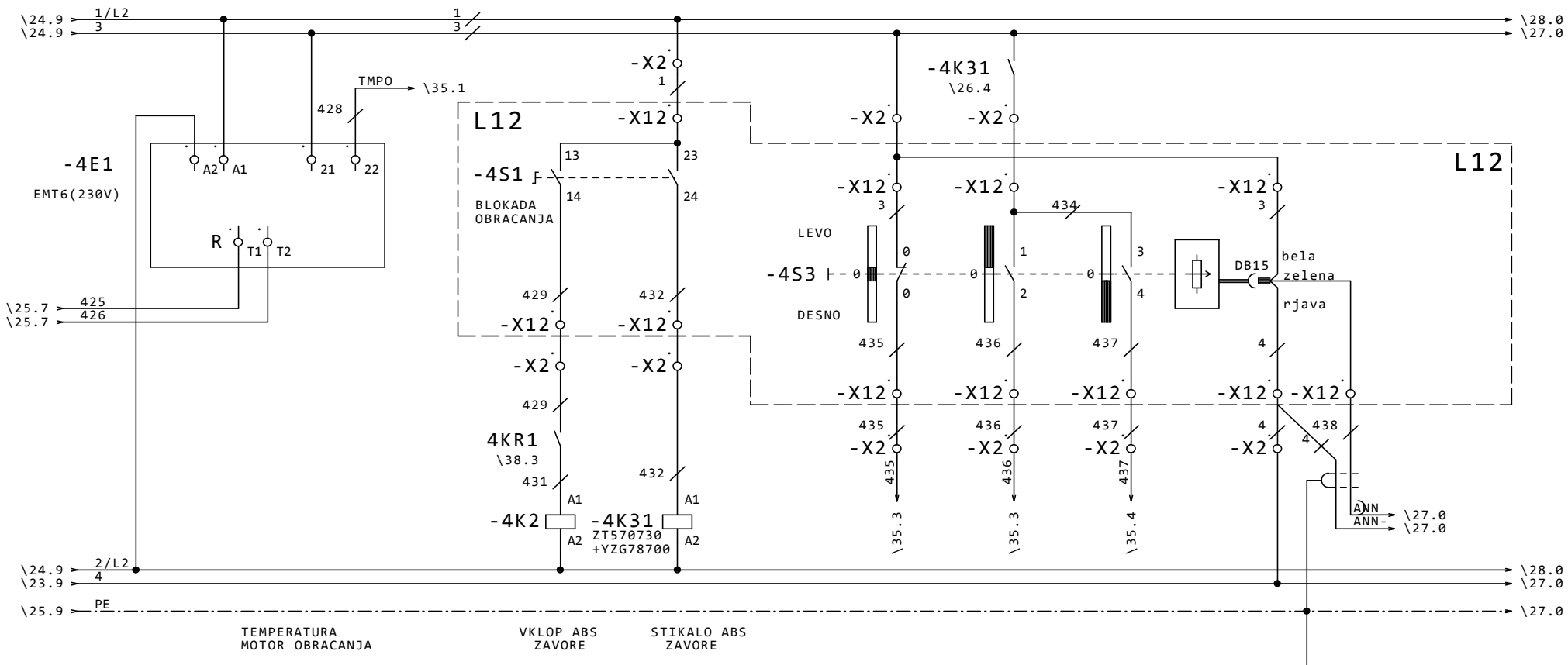

TEMPERATURA MOTOR OBRACANJA

VKLOP ABS ZAVORE

STIKALO ABS ZAVORE

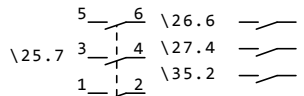

### MOJSTRSKO STIKALO OBRACANJA



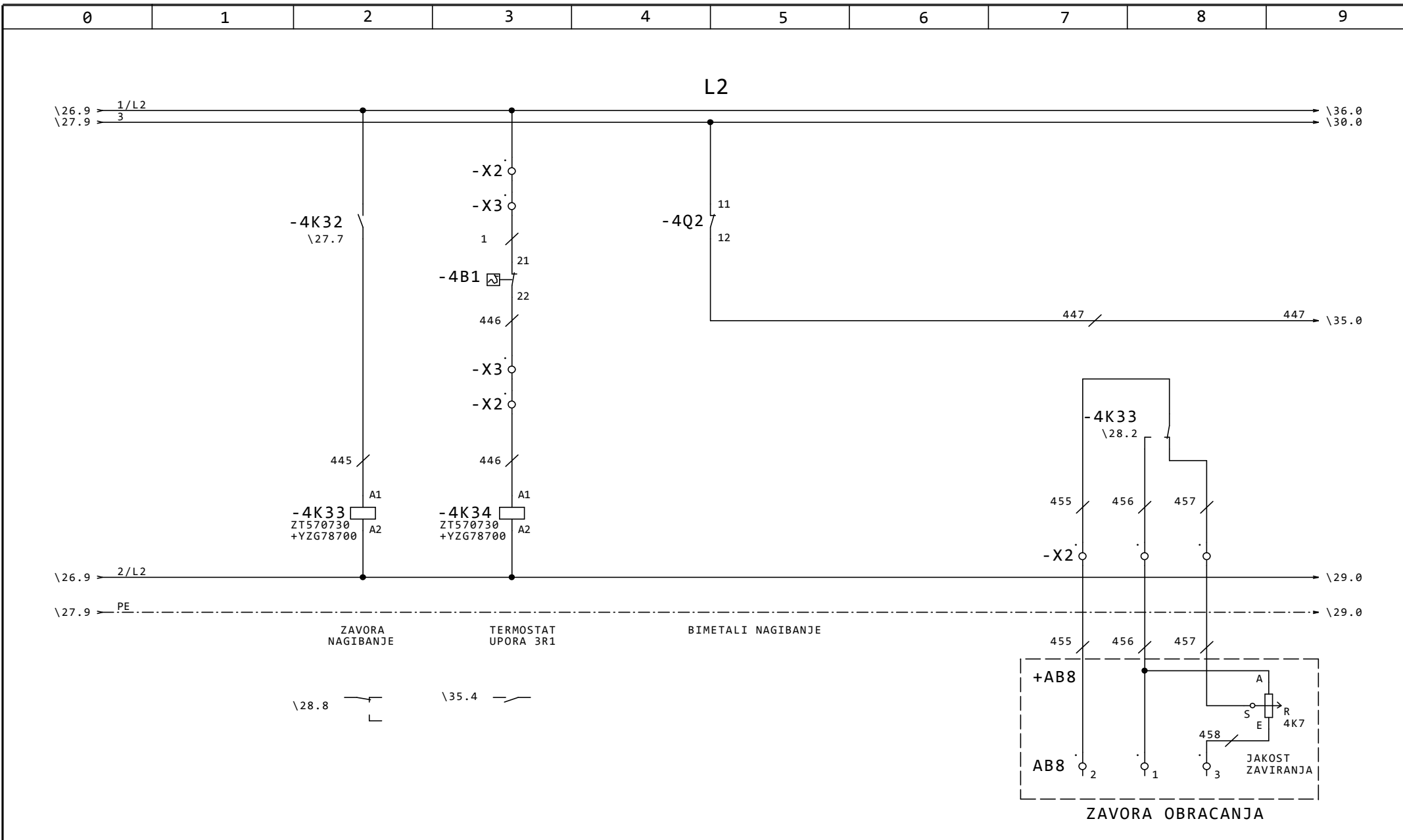

<b>ROBOTINA d.o.o.</b> Oprema in sistemi za avtomatizacijo TEL: 05 66 32 420 Ident. št.: IZS 1628	verzija:	PID 1.0	ident. št.:	E-1012	datum:	24.09.01	podpis:	Pristaniški žerjav z grabilcem 20/10Mp x 25/30m 	LUKA KOPER d.d. PC Terminal Sipki Tovori	OBRAČUNJE KRMILNI DEL V L2		Št. projekta: <b>01-06-023</b>	-2-04-4/4 Skupina	Stran: 28 Strani: 38
	odg. proj.:	Ivan Morano								0				
	risal:													
	pregledal:													
Objekt									Investitor					

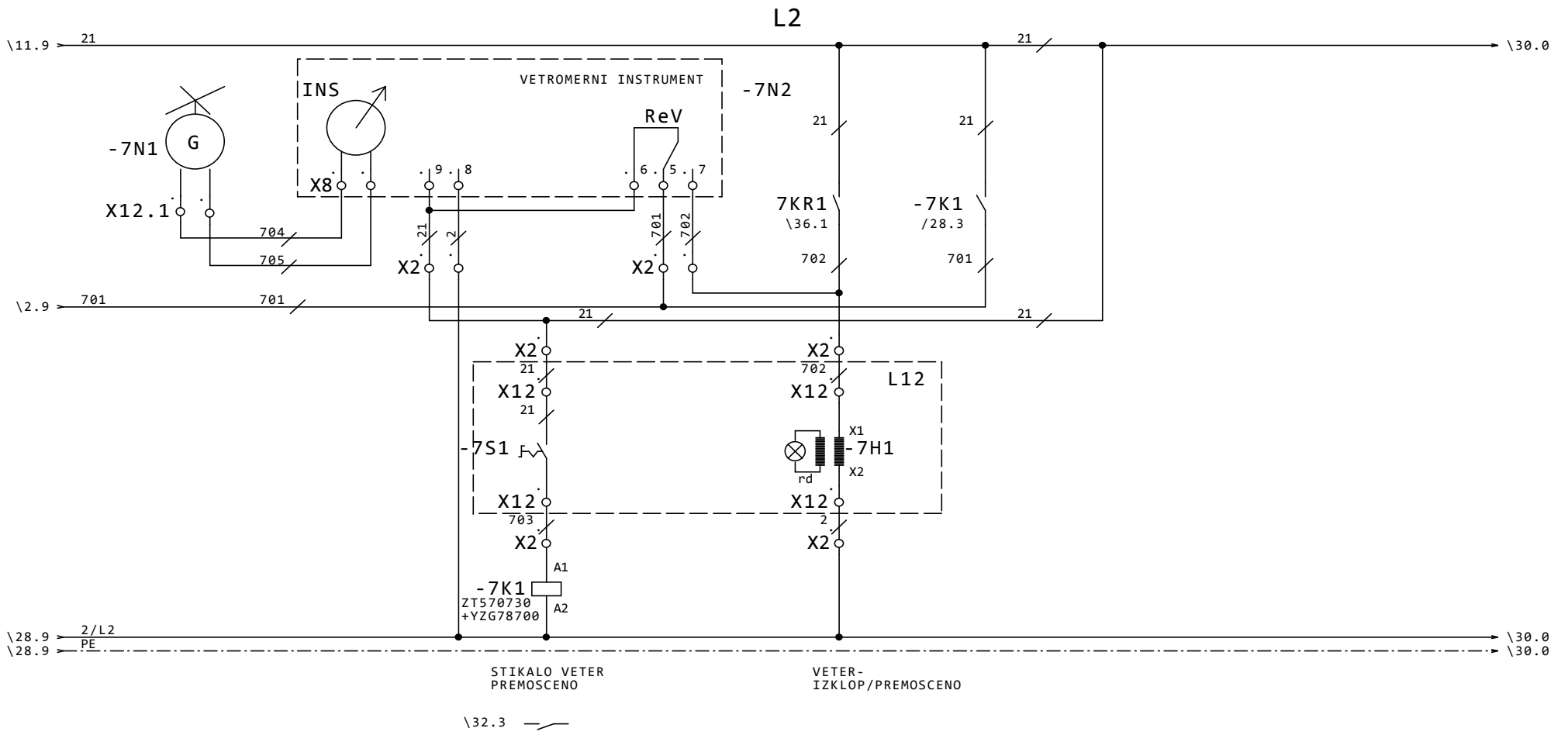



**UNIOP**  
15-pin, ženski (DB-15 F)

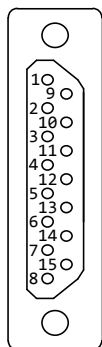

POGLED SPREDAJ

**EH-150**  
8-pin, tel.,moški (RJ 45) 8/8

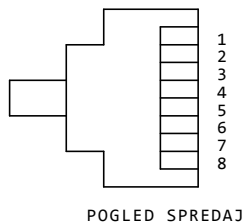
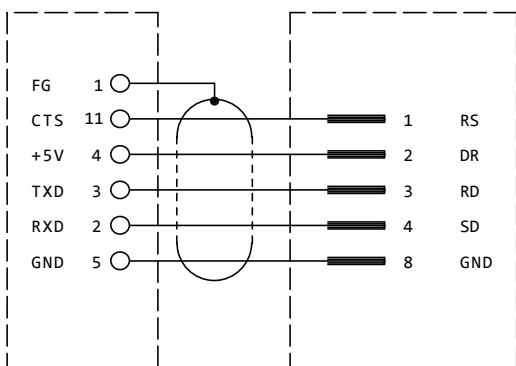

POGLED SPREDAJ

**RADIJSKI MODEM**  
9-pin, moški (DB-9M)

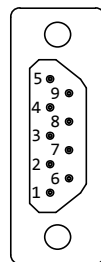

POGLED SPREDAJ

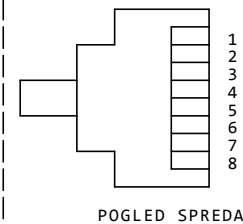
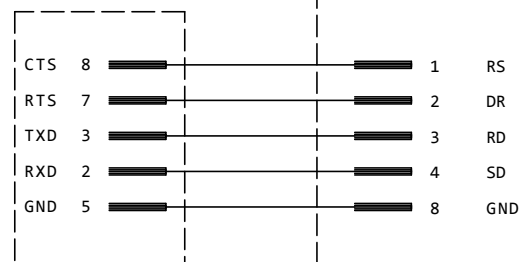

POGLED SPREDAJ

**PROFIBUS**  
9-pin, ženski (DB-9F)

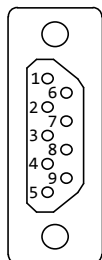

POGLED SPREDAJ

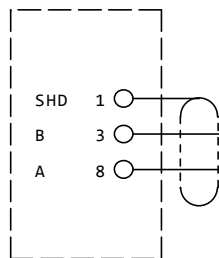

**PROFIBUS**  
9-pin, ženski (DB-9F)

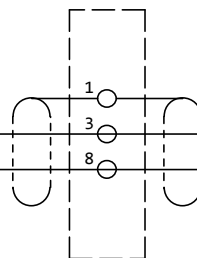

**PROFIBUS**  
9-pin, ženski (DB-9F)

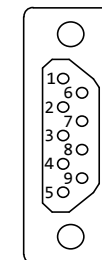
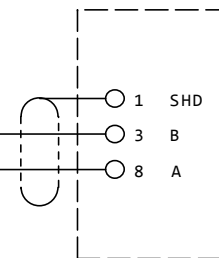

POGLED SPREDAJ





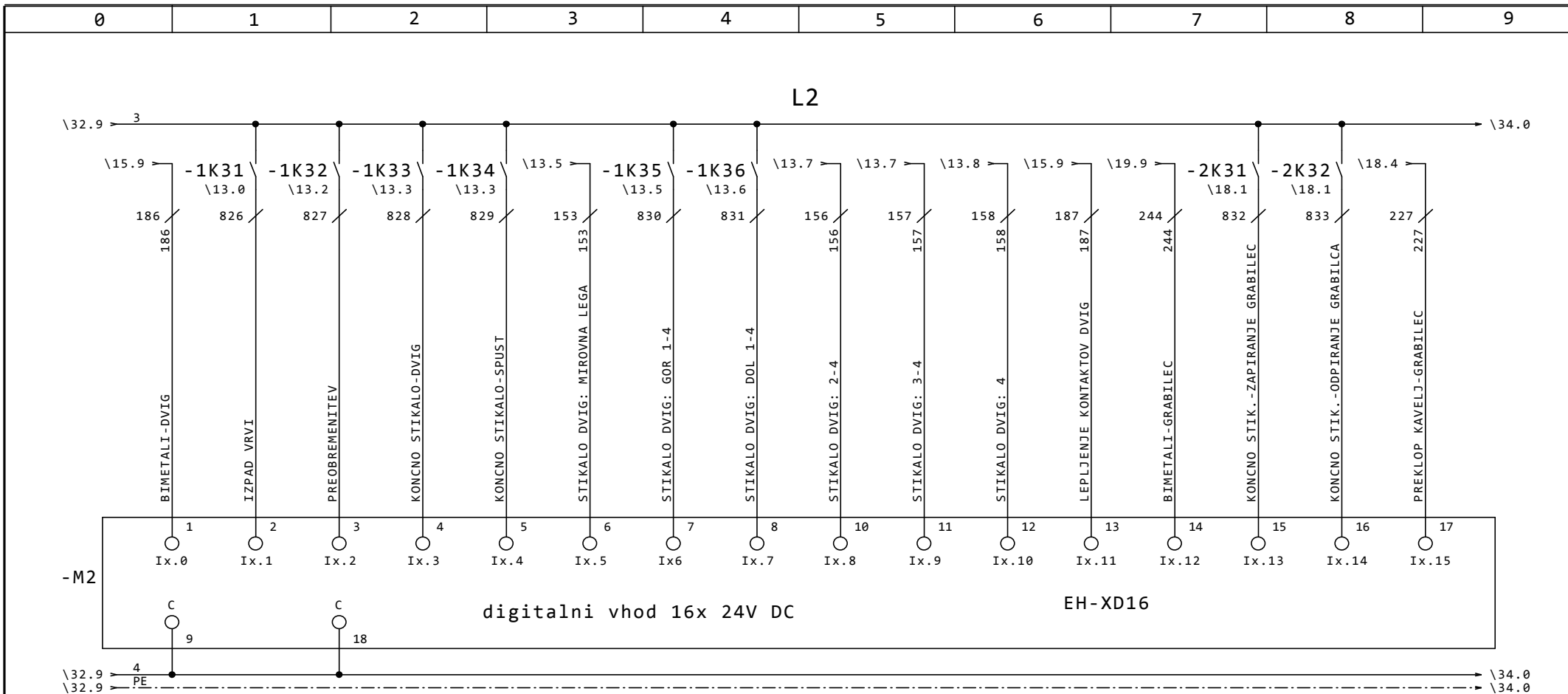

<b>ROBOTINA d.o.o.</b> Oprema in sistemi za avtomatizacijo TEL: 05 66 32 420 Ident. št.: IZS 1628	verzija:	PID 1.0	ident. št.:	datum:	podpis:	Pristaniški žerjav z grabilcem 20/10Mp x 25/30m 	LUKA KOPER d.d. PC Terminal Sipki Tovori Investitor	PLC KRMILNIK KRMILNI DEL V L2		PLC	=8		
	odg. proj.:	Ivan Morano	E-1012	24.09.01							+L2		
	risal:												Št. projekta: 01-06-023
	pregledal:												-2-04-8/4 Skupina
Objekt						Investitor							



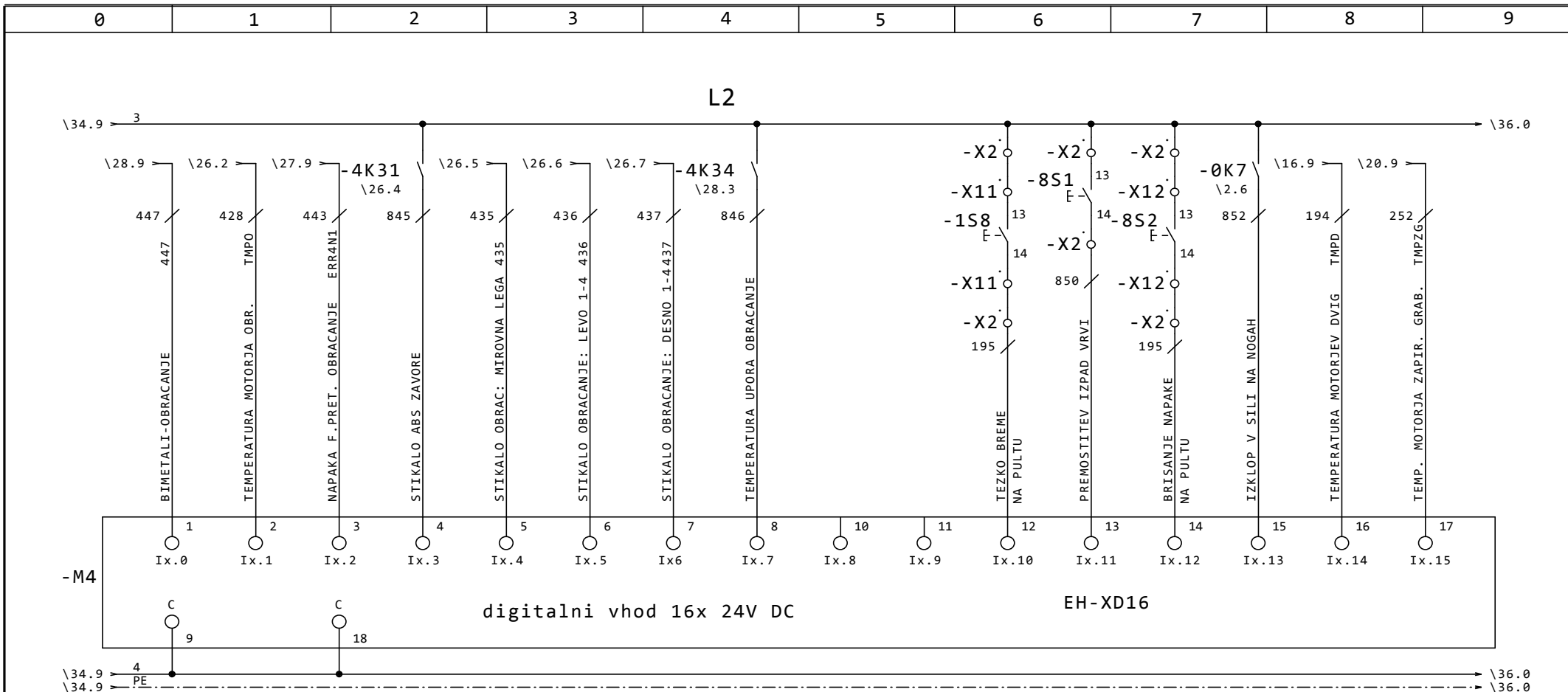

<b>ROBOTINA d.o.o.</b> Oprema in sistemi za avtomatizacijo TEL: 05 66 32 420 Ident. št.: IZS 1628	verzija:	PID 1.0	ident. št.:	datum:	podpis:	Pristaniški žerjav z grabilcem 20/10Mpx 25/30m 	LUKA KOPER d.d. PC Terminal Sipki Tovori Investitor	PLC KRMILNIK KRMILNI DEL V L2		PLC	=8
	odg. proj.:	Ivan Morano	E-1012	24.09.01				Št. projekta: <b>01-06-023</b>	-2-04-8/6 Skupina	Stran: 35	
	risal:									Strani: 38	
	pregledal:										
Objekt						Investitor					



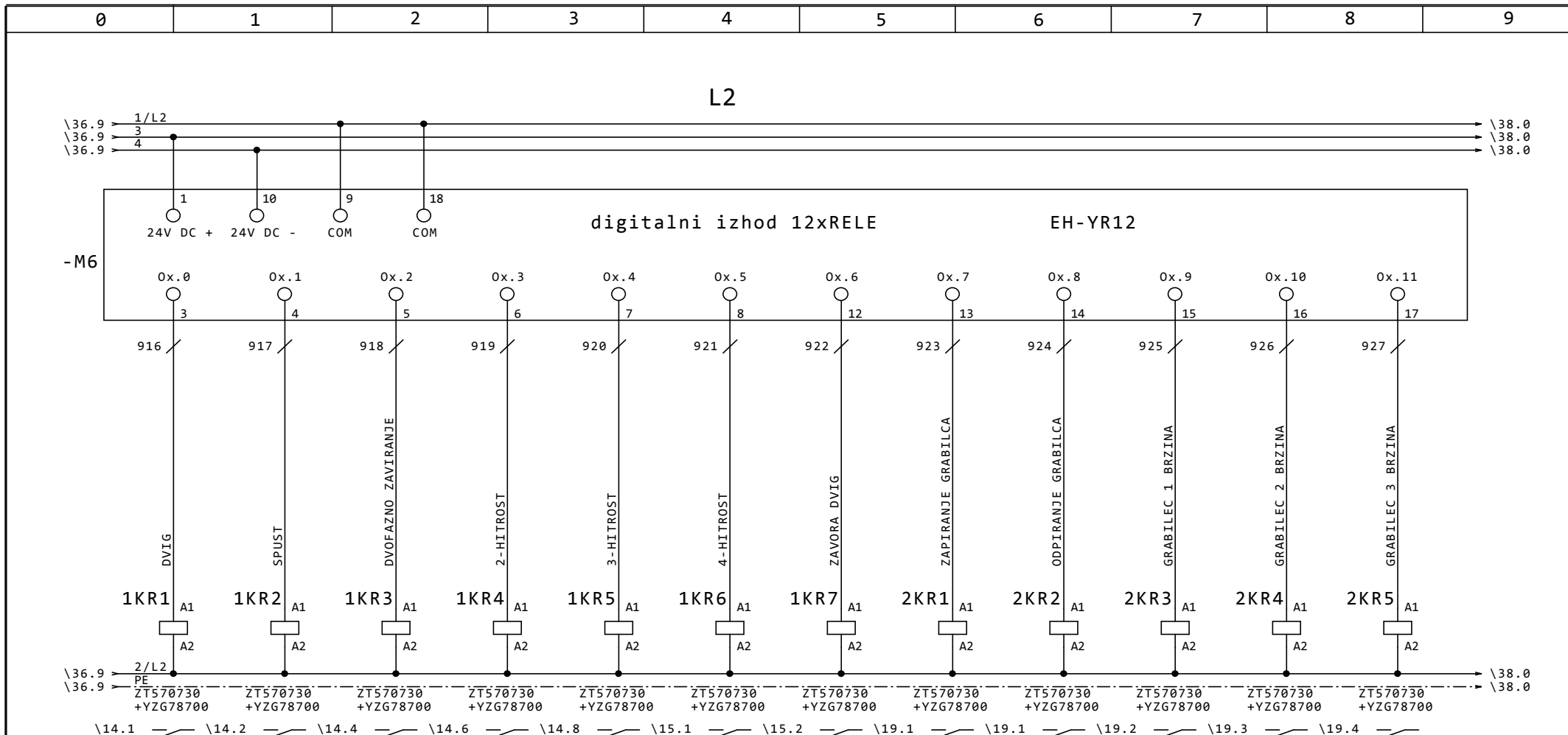

<b>ROBOTINA d.o.o.</b> Oprema in sistemi za avtomatizacijo TEL: 05 66 32 420 Ident. št.: IZS 1628	verzija:	PID 1.0	ident. št.:		datum:		podpis:		Pristaniški žerjav z grabilcem 20/10Mp x 25/30m 	LUKA KOPER d.d. PC Terminal Sipki Tovori Investitor	PLC KRMILNIK KRMILNI DEL V L2		PLC	=8	
	odg. proj.:	Ivan Morano	E-1012		24.09.01										+L2
	risal:														
pregledal:									Objekt		Št. projekta: 01-06-023		-2-04-8/8 Skupina	Stran: 37 Strani: 38	

## L2

